

PTR21 _REV10

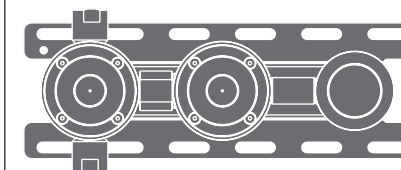

REGISTERED PATENT
CEADESIGN

AISI 304 STAINLESS STEEL

Corpo incasso universale che permette una regolazione in profondità nella parete

Universal built-in part that allows to adjust its depth into the wall



! Il flusso combinato riguarda la seconda e terza via.
To permit the use of combined flow, you have to consider the second and the third outlets.

PRODOTTI CORRELATI / RELATED PRODUCTS

BAR69 - BAR69Y - CRX20 - CRX20Y - GIO54 - GIO54Y
ZIQ71 - ZIQ71Y

Questi disegni sono proprietà di CEADESIGN SRL s.u. pertanto non potranno essere utilizzati e/o comunicati a terzi, anche in forma parziale, senza preventiva autorizzazione. CEADESIGN SRL s.u. si riserva il diritto di apportare modifiche ai disegni al fine di migliorare il prodotto.

CEADESIGN SRL s.u. has the property rights on these drawings, therefore they cannot be used and/or transferred to third party, even in partial form, without any prior authorization. Furthermore CEADESIGN SRL s.u. reserves the right to apply any change to these drawings in order to upgrade the product.

cea

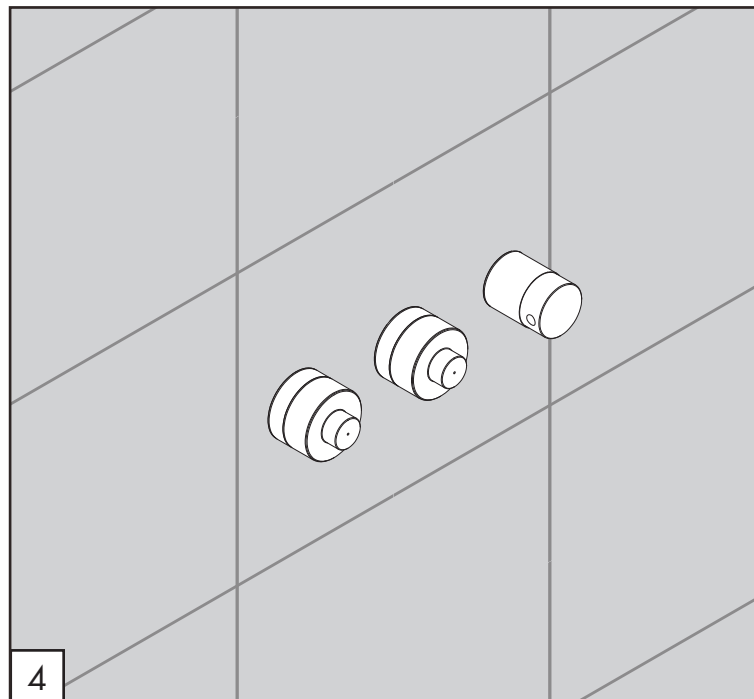
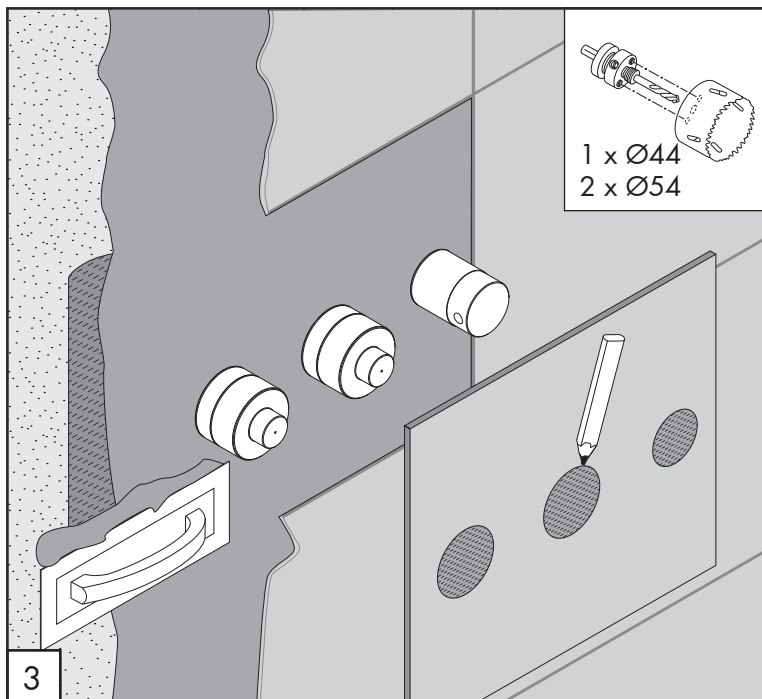
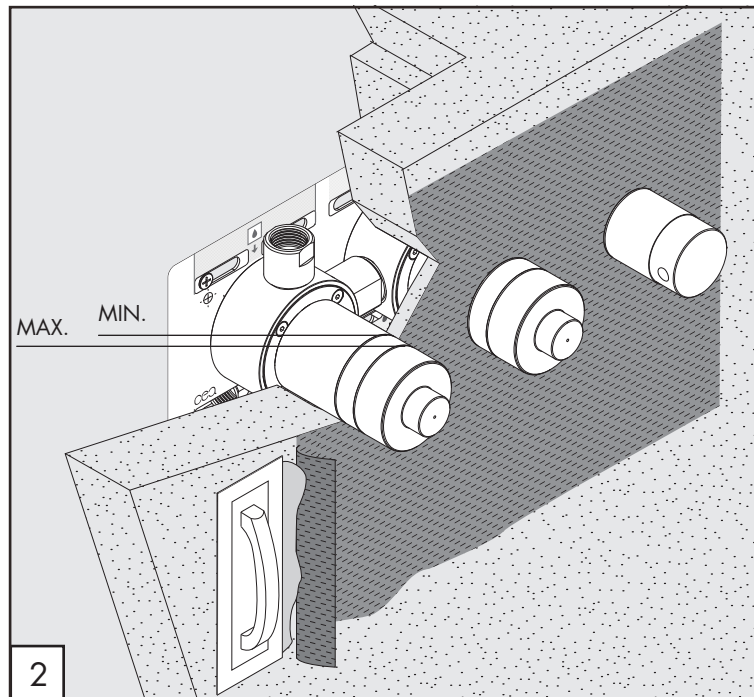
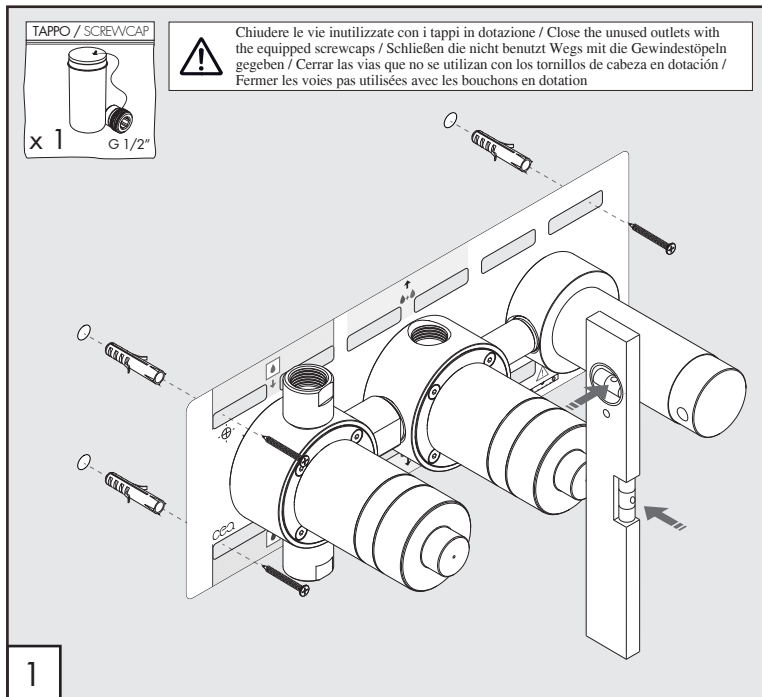

PTR21

_REV10



AVVERTENZE TECNICHE

Risciacquare bene le tubazioni prima del montaggio ed evitare sbalzi di pressione fra i raccordi d'acqua fredda e d'acqua calda. In caso di pressioni statiche superiori a 5 bar si raccomanda l'installazione di un riduttore di pressione per evitare danni alla cartuccia.

TECHNICAL WARNINGS

The pipes have to be rinsed thoroughly before installation. Avoid pressure differences between hot and cold water supply. Use of a pressure reducer when static pressure is higher than 5 bar to avoid damage of the cartridge.

TECHNISCHE WARNUNG

Spülen Sie die Leitungen vor dem Einbau und verhindern Sie Wasserdruckwechsel zwischen kalt und warm Wasserverbindungen. Wenn Wasserdruck größer als 5 bar ist, bitte reduzieren Sie den Systemdruck, um Beschädigung der Kartusche zu verhindern.

ADVERTENCIA TÉCNICA

Los tubos tienen que ser enjuagados a fondo antes de la instalación. Evitar grandes diferencias de presión entre las conexiones de agua caliente y fría. En caso de presión estática mayor de 5 bar, se recomienda el uso de un adaptador de presión para evitar daños en el cartucho.

ADVERTISSEMENTS TECHNIQUES

Rincer les tuyaux avant l'installation. Eviter des grandes différences de pression entre l'eau froide et chaude. En cas de pressions statique de plus de 5 bar, nous vous recommandons d'installer un réducteur de pression pour éviter des dommages à la cartouche.

PORTATE / FLOW RATE

BAR	uscita 1 / outlet 1		uscita 2 / outlet 2	
	l/min	gpm	l/min	gpm
1	11,2	2.9	10.1	2.7
2	15,8	4.2	14.3	3.8
3*	19,2	5.1	17.5	4.6
4	22,0	5.8	20.1	5.3
5	24,9	6.6	22.6	6.0

BAR	uscita 3 / outlet 3	
	l/min	gpm
1	11.7	3.1
2	16.6	4.4
3*	20.2	5.3
4	23.3	6.2
5	26.1	6.9

* Pressione consigliata
Recommended pressure

 max. 70 °C
max. 158 °F

CEA

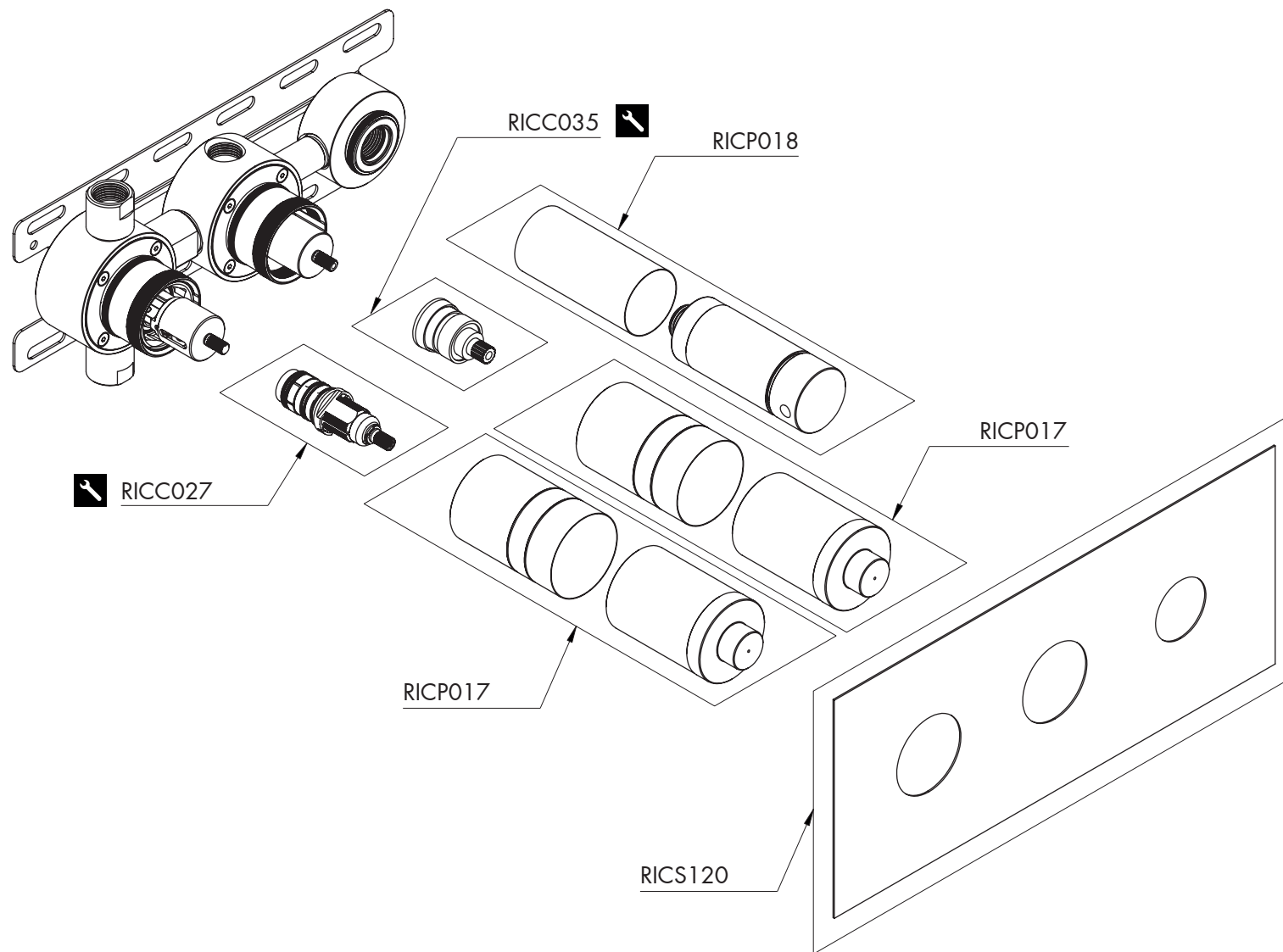

RICAMBI / SPARE PARTS

RICC027	Cartuccia / Cartridge
RICC035	Cartuccia / Cartridge
RICP017	Copertura di protezione / Protective covering
RICP018	Copertura di protezione / Protective covering
RICS120	Membrana di isolamento / Insulation membrane

LEGENDA / LEGEND

ICONE / ICONS

 Utensile incluso nel ricambio
Tool included in spare part